



HARLYN

Products

Price Guide 2026

RRP

premium product solutions



Welcome to the Harlyn Products Dealer Price Guide

Your comprehensive price list for premium sinks and taps designed to improve any kitchen space.

At Harlyn, we pride ourselves on offering an exclusive range of high-quality products, including our signature Harlyn Sinks & Taps. Our collection features a stunning variety of stainless steel, granite and ceramic sinks, alongside an innovative selection of taps, including boiling and filter taps that cater to the modern consumer's needs.

In addition to our flagship offerings, we are proud to present Rocklite, the best composite sink product on the market, known for its durability and aesthetic appeal. We also feature the McAlpine Kitchen Taps range, a testament to our commitment to quality, as McAlpine is recognised as a market leader in plumbing solutions.

Our management team brings over 50 years of combined experience in the industry. We founded Harlyn Products Limited with a clear mission: to provide premium product solutions backed by exceptional customer service. We understand the importance of reliability and quality in your business and we are dedicated to supporting you with our extensive product knowledge and commitment to excellence.

Thank you for choosing Harlyn Products Limited. We look forward to partnering with you to meet your sink and tap needs and to help you deliver outstanding solutions to your customers.



premium product solutions



HARLYN

Products

Contents

Harlyn Sinks

Sennen	4
Daymar	6
Towan	7
Carbis	8 - 9

Rocklite Sinks

Bredon	11
Milton	13
Weston	14

Whitebirk Sinks

The Classic Collection	18 - 21
The Rill Collection	22 - 23
The Understone Collection	24 - 26
The Workstead Collection	27
Accessories	28 - 29

Harlyn Taps

Harlyn Hot Water Taps

McAlpine Taps

Terms & Conditions

Payment & Delivery

Contact Us



HARLYN

Sinks

Discover the perfect blend of style and functionality with Harlyn Sinks.

Our exquisite range, available in both stainless steel and granite, caters to every budget and installation preference, including inset and undermount options.

Crafted from premium materials, our stainless steel sinks utilise medical grade stainless steel, while our granite sinks feature innovative SCHOCK technology, ensuring durability and resilience.

Our commitment to quality means, each Harlyn sink comes with a lifetime guarantee against manufacturing defects, providing you with peace of mind and a beautiful centrepeice for your kitchen.

*Transform your space with
Harlyn Sinks, where elegance
meets excellence.*



HARLYN
Sinks & Taps

Harlyn Sennen

Undermount



All Sennen sinks are 80% Quartz content with ULTRA CLEAN anti-bacterial formula and supplied with a full space saver plumbing kit.

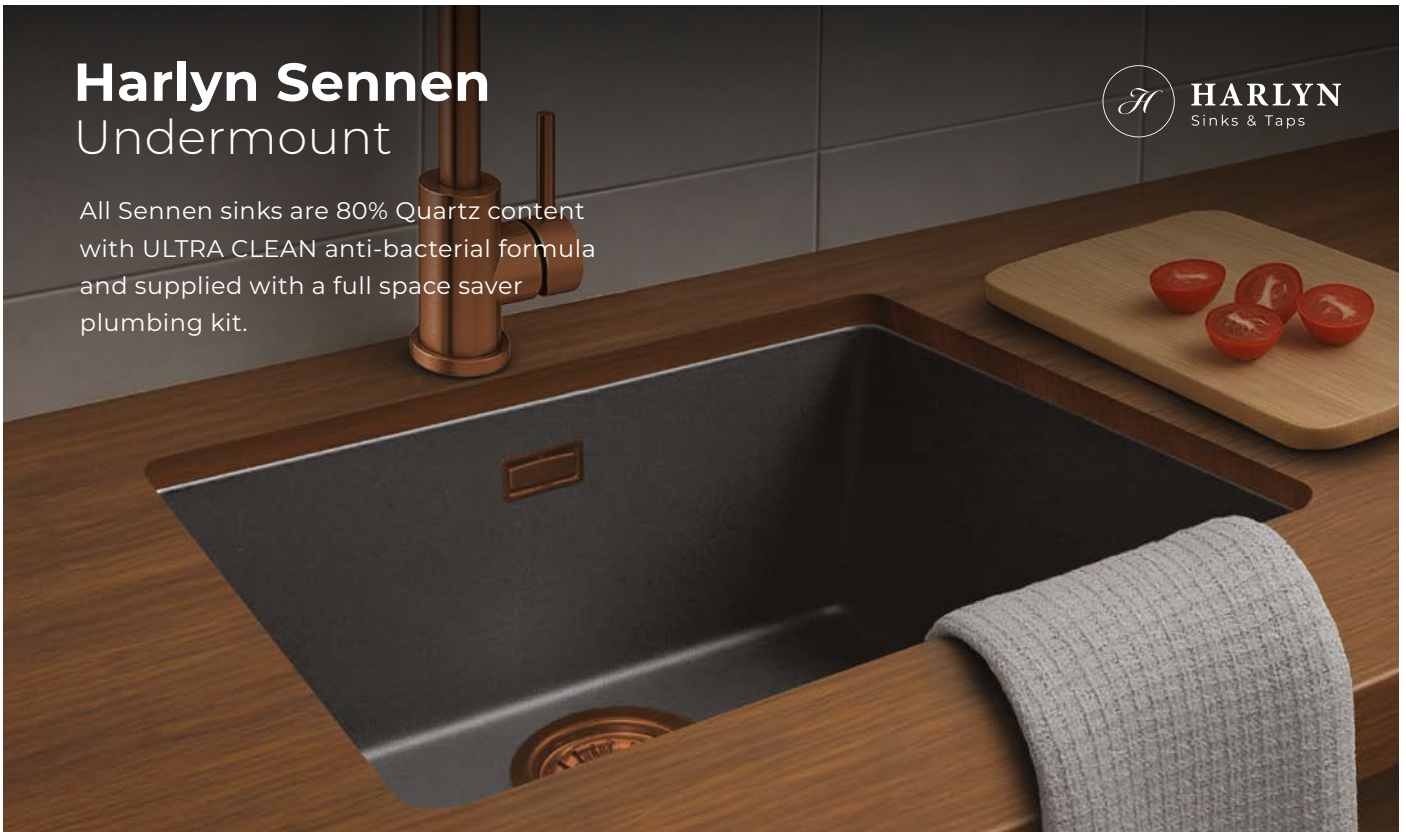

Inset and Undermount
Single Bowl

Inset and Undermount
1.5 Bowl

Inset and Undermount
Large Single Bowl

SENNEN100BL	Black
SENNEN100WH	White
SENNEN100GR	Grey
Internal Bowl Dimensions	400mm x 400mm
RRP	£226.81

SENNEN150BL	Black
SENNEN150WH	White
SENNEN150GR	Grey
Internal Bowl Dimensions	555mm x 460mm
RRP	£263.74

SENNEN200BL	Black
SENNEN200WH	White
SENNEN200GR	Grey
Internal Bowl Dimensions	500mm x 400mm
RRP	£234.73

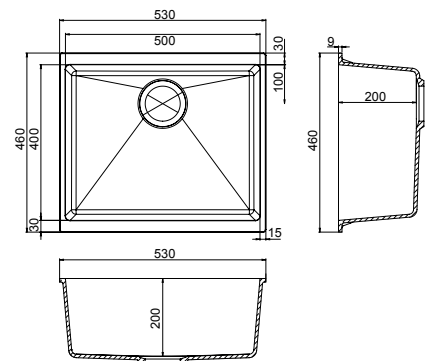
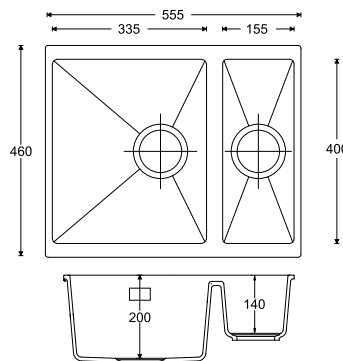
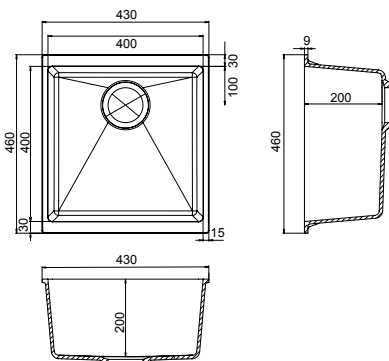

Harlyn Daymer

Inset

All Daymer sinks are **80% Quartz** content with **ULTRA CLEAN** anti-bacterial formula and supplied with a full space saver plumbing kit.



BL GR WH

Inset Compact
Single Bowl & Drainer

Inset Large
Single Bowl & Drainer

Inset 1.5
Bowl & Drainer

DAYMER100BL	Black
DAYMER100WH	White
DAYMER100GR	Grey
Internal Bowl Dimensions	860mm x 500mm
RRP	£269.01

DAYMER200BL	Black
DAYMER200WH	White
DAYMER200GR	Grey
Internal Bowl Dimensions	1000mm x 500mm
RRP	£276.92

DAYMER150BL	Black
DAYMER150WH	White
DAYMER150GR	Grey
Internal Bowl Dimensions	1000mm x 500mm
RRP	£282.20

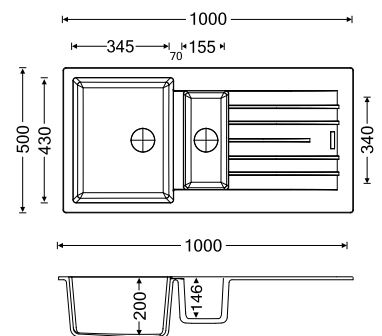
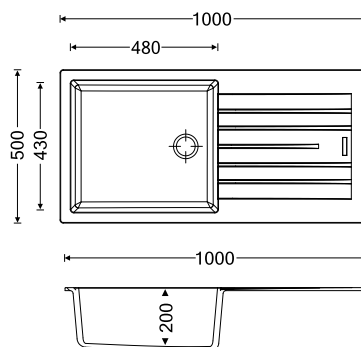
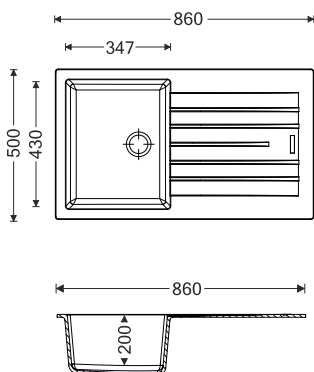

Harlyn Towan

Inset

All Towan Sinks are manufactured from Medical Grade stainless steel.

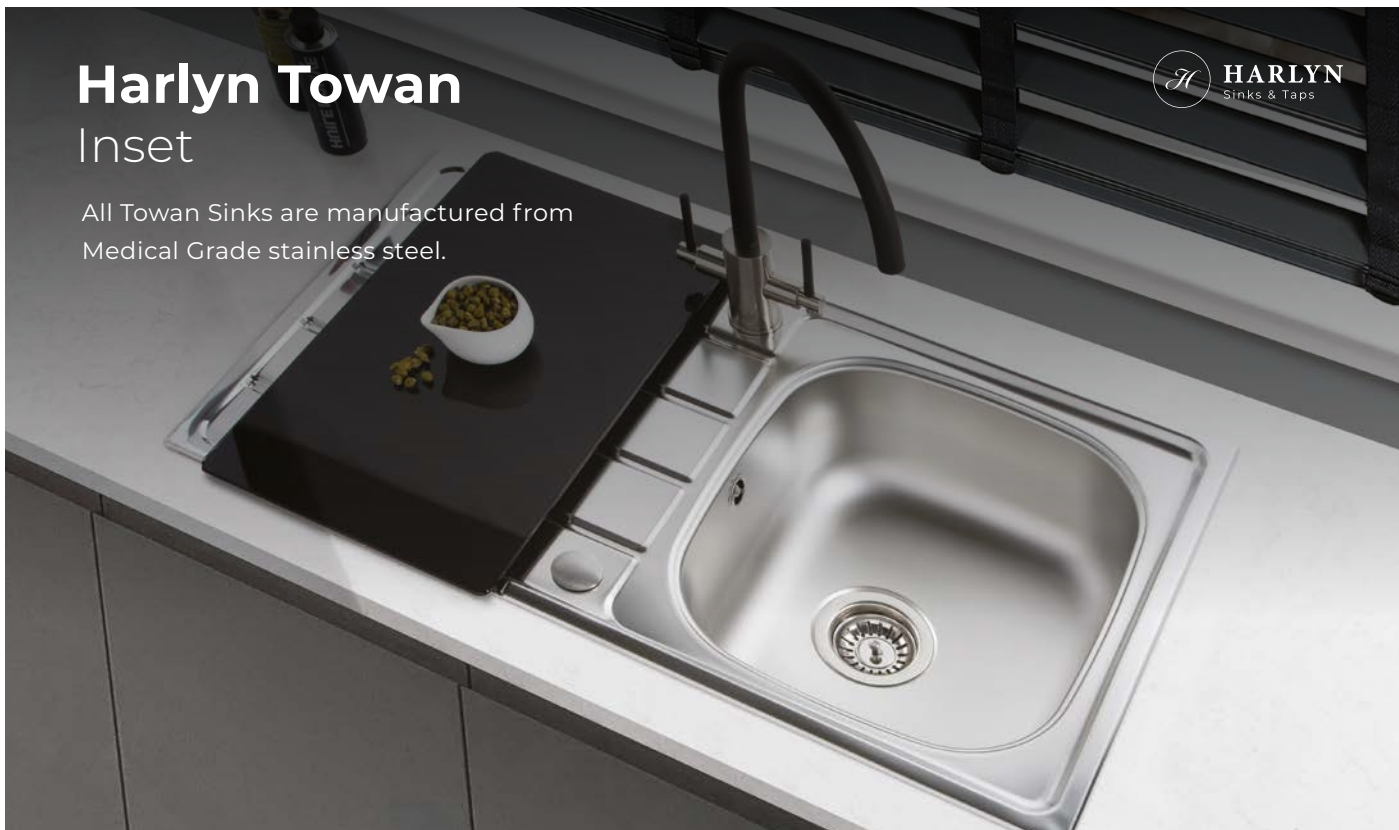

Compact Single Bowl & Drainer
Reversible (round overflow)

Large Single Bowl & Drainer
Reversible (round overflow)

1.5 Bowl & Drainer
Reversible (round overflow)

TOWAN100	Stainless Steel
Dimensions	860mm x 500mm
RRP	£142.86

TOWAN200	Stainless Steel
Dimensions	965mm x 500mm
RRP	£148.57

TOWAN150	Stainless Steel
Dimensions	965mm x 500mm
RRP	£154.29

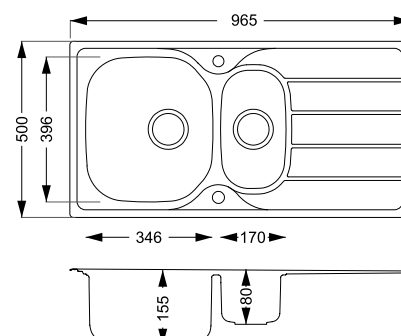
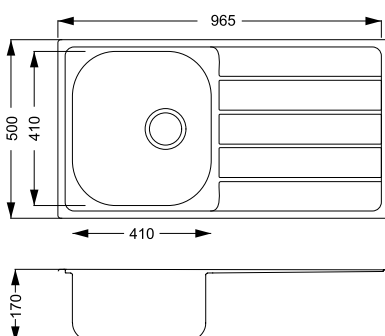
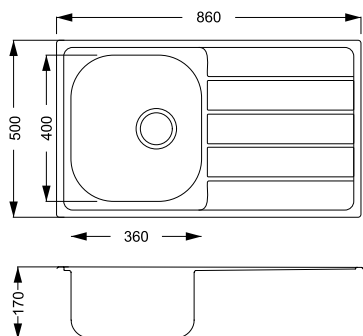

Harlyn Carbis

Undermount/Inset

All Carbis Sinks are manufactured from premium grade stainless steel.



1.5 Bowl Pressed Radius 10
Inset/Undermount

1.5 Bowl Pressed Radius 10
Inset/Undermount

1.5 Bowl Pressed Radius 10
Inset/Undermount

CARBIS150LH/RH	Stainless Steel
Dimensions	340mm x 400mm 180mm x 400mm
RRP	£271.65

CARBIS150LHL/RHL	Stainless Steel
Dimensions	410mm x 400mm 180mm x 400mm
RRP	£290.11

CARBIS150LHXL/RHXL	Stainless Steel
Dimensions	550mm x 400mm 180mm x 400mm
RRP	£303.30

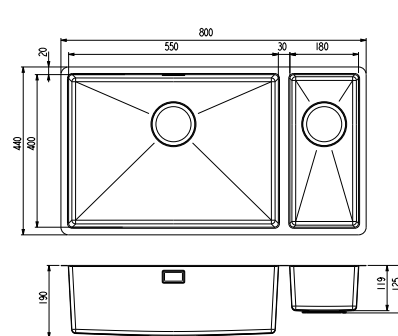
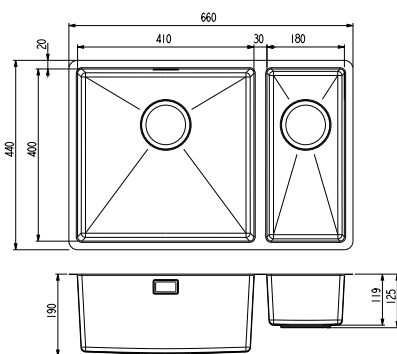
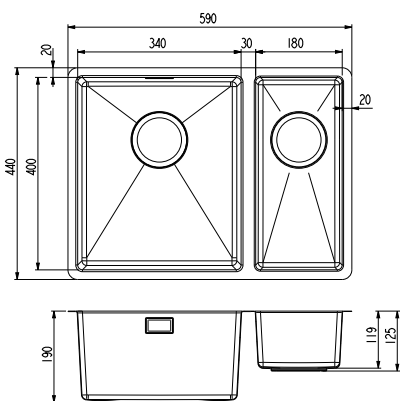



Single Bowl Pressed Radius 10
Inset/Undermount

CARBIS100	Stainless Steel
Dimensions	340mm x 400mm
RRP	£195.16

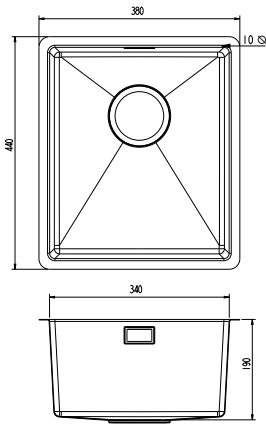

Single Bowl Pressed Radius 10
Inset/Undermount

CARBIS110	Stainless Steel
Dimensions	410mm x 400mm
RRP	£208.35

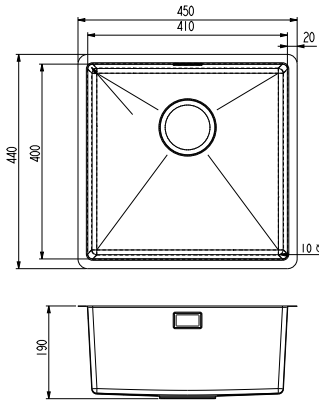

Large Single Bowl Pressed Radius 10
Inset/Undermount

CARBIS120	Stainless Steel
Dimensions	550mm x 400mm
RRP	£216.26

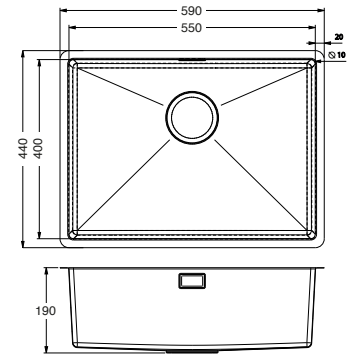

Large Single Bowl Pressed Radius 10
Inset/Undermount

CARBISPVD110GD CARBISPVD110CO CARBISPVD110GM	PVD Stainless Steel
Dimensions	550mm x 400mm
RRP	£321.76

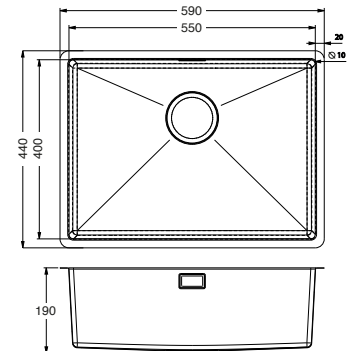

1.5 Bowl Reversible Pressed Radius 10
Inset/Undermount

CARBISPVD150GD CARBISPVD150CO CARBISPVD150GM	PVD Stainless Steel
Dimensions	340mm x 400mm 180mm x 400mm
RRP	£374.51

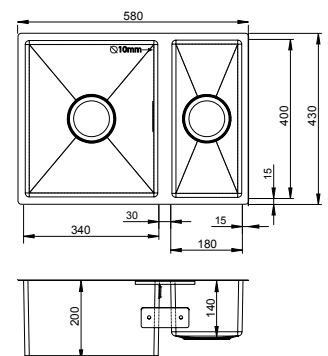

Composite Sinks

Strength in its lightest form

ROCKLITE sinks are moulded on hydraulic presses. The material is applied in the press and then the sink is formed under pressure and heat.



SMC Benefits



RESISTANCE TO MECHANICAL SHOCKS

Very resistant material to shocks.
Easy to handle and to ship.



LIGHTNESS

Ultra-light material, easy to ship and install: on average 5 kg for a 1 bowl sink.



RESISTANCE TO STAINS

Tests done by independent accredited laboratory.



RESISTANCE TO HEAT

Material resistant to dry heat (180 Celsius degrees).



FOOD CONTACT

Material certified food contact by an independent accredited laboratory.



LONG-LASTING COLOURS

100% mass-coloured.
Easy to clean.



EASY TO DRILL

For tap installation.

Rocklite Bredon - SMC

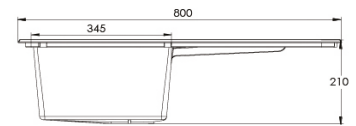
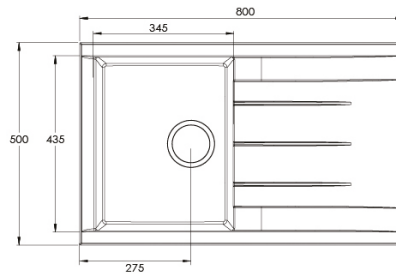

RO6 R16 R17

Product Code	EAN	Description	Colours	Dimensions (MM)	Bowl	RRP
Bredon1BL	3660428008797	1.0 Bowl Black Composite Reversible	Shimmering Black - R06	800 x 500 x 210	1	£125.69
Bredon1GR	3660428008803	1.0 Bowl Grey Composite Reversible	Beton Grey - R16	800 x 500 x 210	1	£125.69
Bredon1WH	3660428008810	1.0 Bowl White Composite Reversible	Plain White - R17	800 x 500 x 210	1	£125.69

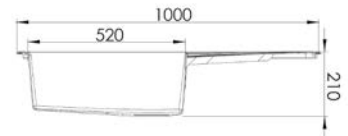
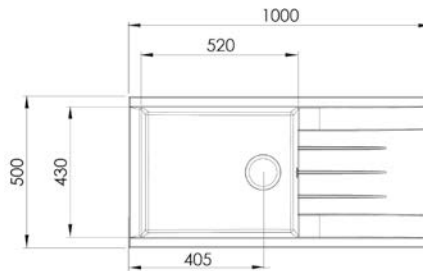

RO6 R16 R17

Product Code	EAN	Description	Colours	Dimensions (MM)	Bowl	RRP
Bredon1x1BL	3660428008827	1.0 Bowl Black Composite Reversible	Shimmering Black - R06	1000 x 500 x 210	1 XL	£134.60
Bredon1x1GR	3660428008834	1.0 Bowl Grey Composite Reversible	Beton Grey - R16	1000 x 500 x 210	1 XL	£134.60
Bredon1x1WH	3660428008841	1.0 Bowl White Composite Reversible	Plain White - R17	1000 x 500 x 210	1 XL	£134.60

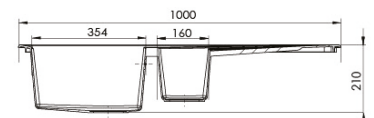
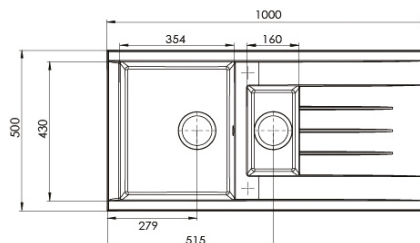

RO6 R16 R17

Product Code	EAN	Description	Colours	Dimensions (MM)	Bowl	RRP
Bredon1.5BL	3660428008858	1.5 Bowl Black Composite Reversible	Shimmering Black - R06	1000 x 500 x 210	1.5	£145.73
Bredon1.5GR	3660428008865	1.5 Bowl Grey Composite Reversible	Beton Grey - R16	1000 x 500 x 210	1.5	£145.73
Bredon1.5WH	3660428008872	1.5 Bowl White Composite Reversible	Plain White - R17	1000 x 500 x 210	1.5	£145.73

Composite Sinks

Strength in its lightest form

ROCKLITE sinks are applied with powder before pressing the sink with a protective coating, which improves scratch resistance.



PIMC Benefits



IMPROVED SCRATCH RESISTANCE

Multilayer material: SMC base, coated with a thin layer of paint (resin), protecting the sink from scratches.



RESISTANCE TO MECHANICAL SHOCKS

Very resistant material to shocks.
Easy to handle and to ship.



RESISTANCE TO STAINS

Tests done by independent accredited laboratory.



FOOD CONTACT

Material certified food contact by an independent accredited laboratory.



LIGHTNESS

Ultra-light material, easy to ship and install: on average 5 kg for a 1 bowl sink.



RESISTANCE TO HEAT

Material resistant to dry heat (180 Celsius degrees).



LONG-LASTING COLOURS

100% mass-coloured.
Easy to clean.



EASY TO DRILL

For tap installation.

Rocklite Milton - PIMC

Inset

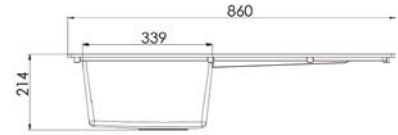
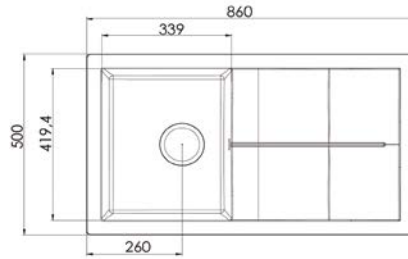

RO6 R16 R17

Product Code	EAN	Description	Colours	Dimensions (MM)	Bowl	RRP
Milton1BL	3660428008704	1.0 Bowl Black Composite Reversible	Shimmering Black - R06	860 x 500 x 210	1	£165.77
Milton1GR	3660428008711	1.0 Bowl Grey Composite Reversible	Beton Grey - R16	860 x 500 x 210	1	£165.77
Milton1WH	3660428008728	1.0 Bowl White Composite Reversible	Plain White - R17	860 x 500 x 210	1	£165.77

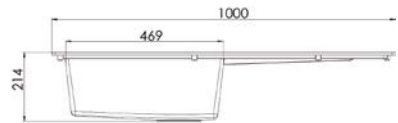
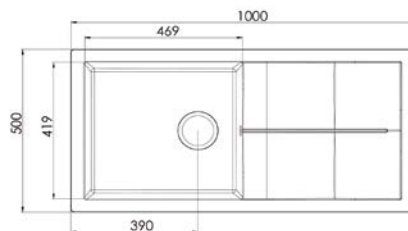

UO6 U16 U17

Product Code	EAN	Description	Colours	Dimensions (MM)	Bowl	RRP
Milton1x1BL	3660428008735	1.0 Bowl Black Composite Reversible	Black - U06	1000 x 500 x 210	1 XL	£174.68
Milton1x1GR	3660428008742	1.0 Bowl Grey Composite Reversible	Dark Grey - U15	1000 x 500 x 210	1 XL	£174.68
Milton1x1WH	3660428008759	1.0 Bowl White Composite Reversible	Plain White - U17	1000 x 500 x 210	1 XL	£174.68

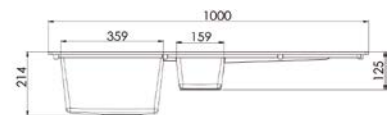
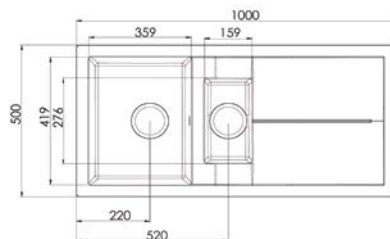

UO6 U15 U17

Product Code	EAN	Description	Colours	Dimensions (MM)	Bowl	RRP
Milton1.5BL	3660428008766	1.5 Bowl Black Composite Reversible	Black - U06	1000 x 500 x 210	1.5	£190.27
Milton1.5GR	3660428008773	1.5 Bowl Grey Composite Reversible	Dark Grey - U15	1000 x 500 x 210	1.5	£190.27
Milton1.5WH	3660428008780	1.5 Bowl White Composite Reversible	Plain White - U17	1000 x 500 x 210	1.5	£190.27

Rocklite Weston

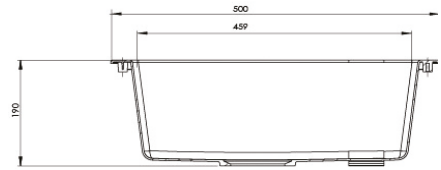
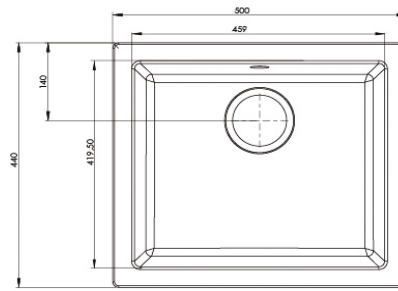

U06 U16 U17

Product Code	EAN	Description	Colours	Dimensions (MM)	Bowl	RRP
WestonBL	3579432002595	Weston 1.0 Bowl Black Composite Inset/undermount	Black - U06	500 x 440 x 190	1	£181.20
WestonGR	3579432002601	Weston 1.0 Bowl Grey Composite Inset/undermount	Dark Grey - U15	500 x 440 x 190	1	£181.20
WestonWH	3.57943E+12	Weston 1.0 Bowl White Composite Inset/undermount	Plain White - U17	500 x 440 x 190	1	£181.20

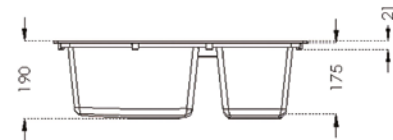
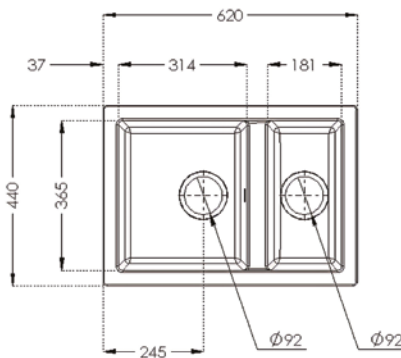
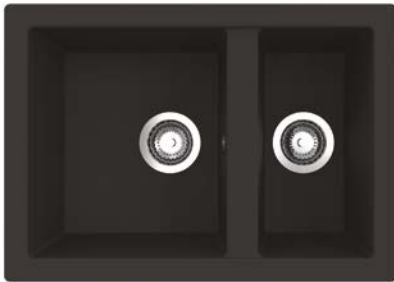

U06 U15 U17

Product Code	EAN	Description	Colours	Dimensions (MM)	Bowl	RRP
Weston1.5BL	5065024651480	Weston 1.5 Bowl Black Composite Inset/undermount	Black - U06	620 x 365 x 190	1.5	£207.92
Weston1.5GR	5065024651497	Weston 1.5 Bowl Grey Composite Inset/undermount	Dark Grey - U15	620 x 365 x 190	1.5	£207.92
Weston1.5WH	5065024651503	Weston 1.5 Bowl White Composite Inset/undermount	Plain White - U17	620 x 365 x 190	1.5	£207.92





WHITEBIRK SINK COMPANY

• ENGLAND •



The Art of Fireclay Sinks

Built to endure, each Whitebirk sink is highly resistant to impact, heat, stains and odours, with a non-porous glazed finish that stays rust-free and fade-resistant for years to come.

Spacious bowl designs make everyday tasks easier, while the timeless aesthetic suits both traditional and modern kitchens.



Whitebirk

The Classic Collection - Apron Front

Classic apron-front sinks with a quiet strength.

Inspired by the quiet grace of open British landscapes, The Classic Collection offers a return to essentials. Featuring our line of single and double bowl sinks with a simple front panel, each piece reflects a sense of calm and clarity, an invitation to simplicity in the heart of the home.





Mellor

Belfast

Mini Belfast

Mellor Single Bowl	Ceramic
Dimensions	595 x 465 x 229 mm
RRP	£349

Belfast Single Bowl	Ceramic
Dimensions	595 x 460 x 255 mm
RRP	£450

Mini Belfast Single Bowl	Ceramic
Dimensions	460 x 380 x 205 mm
RRP	£450



Cleveleys

Samlesbury

Cleveleys Single Bowl	Ceramic
Dimensions	595 x 460 x 226 mm
RRP	£450

Samlesbury Single Bowl	Ceramic
Dimensions	795 x 460 x 254 mm
RRP	£799

Whitebirk

The Classic Collection - Apron Front





Lostock

Pendleton

Lostock Double Bowl	Ceramic
Dimensions	795 x 465 x 220 mm
RRP	£900

Pendleton Double Bowl	Ceramic
Dimensions	800 x 500 x 220 mm
RRP	£850



Ribbleton

Stonyhurst

Ribbleton Double Bowl	Ceramic
Dimensions	895 x 465 x 229 mm
RRP	£949

Stonyhurst Double Bowl	Ceramic
Dimensions	1000 x 535 x 220 mm
RRP	£1,150

Whitebirk

The Rill Collection - Undermount & Inset

Fluted-front sinks inspired by the movement of water.

Defined by its distinctive fluted front panel, The Rill Collection celebrates movement, texture and the artistry of traditional British craftsmanship. Named after the gentle streams that weave through the countryside, each sink evokes the rhythm of water graceful, purposeful and enduring.





Barley

Fluted Lostock

Barley Single Bowl	Ceramic
Dimensions	595 x 460 x 220 mm
RRP	£550

Fluted Lostock Double Bowl	Ceramic
Dimensions	795 x 465 x 220 mm
RRP	£1,099



Warton

Trawden

Warton Double Bowl	Ceramic
Dimensions	895 x 465 x 235 mm
RRP	£1,150

Trawden Double Bowl	Ceramic
Dimensions	1000 x 535 x 220 mm
RRP	£1,350

Whitebirk

The Understone Collection - Undermount & Inset

Undermount and inset sinks for a seamless finish.

Inspired by the quiet resilience of Britain's dry stone walls - structures that have stood for centuries without fanfare. The Understone Collection celebrates strength beneath the surface.





Singleton



Croston

Singleton Single Bowl	Ceramic
Dimensions	445 x 445 x 197 mm
RRP	£400

Croston Single Bowl	Ceramic
Dimensions	462 x 462 x 220 mm
RRP	£400



Freckleton



Bispham

Freckleton Single Bowl	Ceramic
Dimensions	601 x 462 x 222 mm
RRP	£420

Bispham Single Bowl	Ceramic
Dimensions	237 x 462 x 223 mm
RRP	£199

Whitebirk

The Understone Collection - Undermount & Inset



Astley

Langho

Astley Double Bowl	Ceramic
Dimensions	596 x 522 x 223 mm
RRP	£450

Langho Double Bowl	Ceramic
Dimensions	840 x 478 x 245 mm
RRP	£1,099



Whitebirk

The Workstead Collection - Workstation



Workstation sinks for flexible, modern living.

Inspired by the idea of the kitchen as a gathering place - a source of nourishment, connection and creativity. The Workstead Collection brings new meaning to the heart of the home.



Wycoller

Wycoller Single Bowl	Ceramic
Dimensions	914 x 483 x 254 mm
RRP	£1,200



Whitebirk

The Accessories Collection

Thoughtfully designed to complement the elegance of Whitebirk fireclay sinks, our accessories blend beauty with purpose.



Standard Basket Strainer

Size	RRP
1.5" Chrome	£85
3.5" Chrome	£60
3.5" Antique Bronze	£96
3.5" Gold	£96
3.5" Brushed Nickel	£96
3.5" Gunmetal	£96
3.5" Nickel	£96
3.5" Satin Gold	£96

Size: 1.5" fits:
Belfast, Mini Belfast and Cleveleys sinks

Size: 3.5" fits:
All sinks, except for Belfast, Mini Belfast and Cleveleys.
Includes overflow kit where applicable



Premium Basket Strainer

Size	RRP
3.5" Chrome	£109
3.5" Gold	£109
3.5" Nickel	£109
3.5" Gunmetal	£109

Size: 3.5" fits:
All sinks, except for Belfast, Mini Belfast and Cleveleys.
Includes overflow kit where applicable

Whitebirk

The Accessories Collection

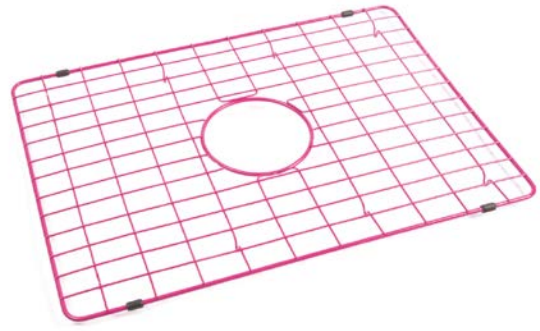
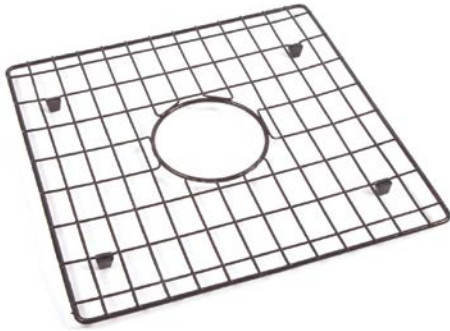

1 x Grids

Colour	RRP
Stainless Steel	£130
Black	£130
White	£130
RAL Colour	£169

2 x Grids

Colour	RRP
Stainless Steel	£199
Black	£199
White	£199
RAL Colour	£220





HARLYN

Taps

Reimagine your kitchen with the Harlyn Tap Collection, a stylish and modern selection designed to enrich any space.

Available in both single and twin lever variants, our taps come in the best selling finishes of Chrome, Matt Black and Brushed Steel, ensuring a perfect match for your décor. Crafted to the highest quality standards, each Harlyn tap boasts full WRAS approval, guaranteeing reliability and performance.

With a 5-year guarantee against manufacturing defects, you can trust that our taps will not only look stunning but also stand the test of time. Experience the perfect blend of style and functionality with the Harlyn Tap Collection.

Harlyn Quin / Pont



Single Lever
Jspout

Twin Lever
J Spout

Quin-MB Matt Black
RRP **£163.52**

Pont-MB Matt Black
RRP **£184.62**

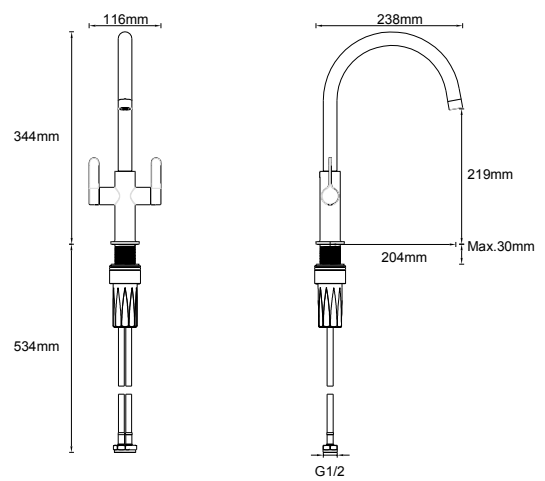
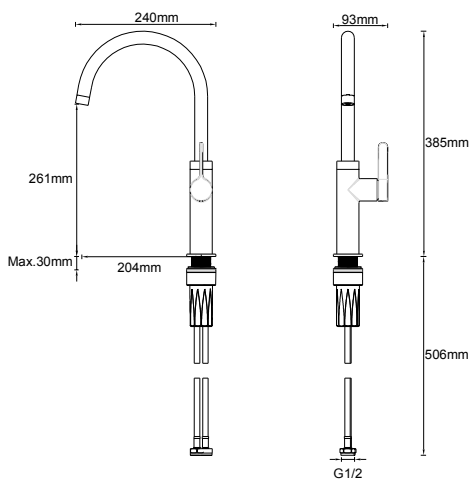





Twin leaver
J Spout - Coloured Spout

Twin leaver
J Spout - Coloured Spout

Holywell-BS	Brushed Steel
RRP	£195.16

Holywell-CH	Chrome
RRP	£181.98

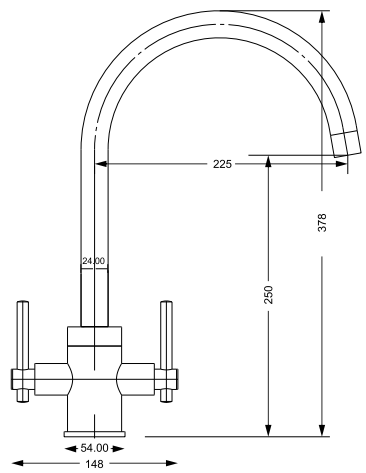





**Twin Leaver
J Spout**

**Twin Leaver
J Spout**

Penpol-BS
RRP

Brushed Steel
£184.62

Penpol-CH
RRP

Chrome
£168.79

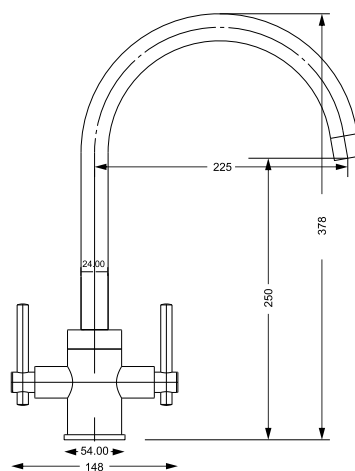





**Single Leaver
J Spout**

**Single Leaver
J Spout**

Treen-BS
RRP

Brushed Steel
£152.97

Treen-CH
RRP

Chrome
£139.78

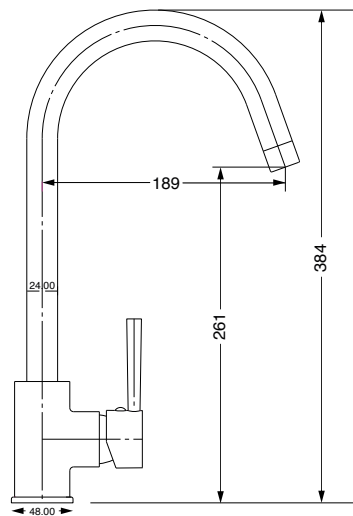



HARLYN

Products

Premium Product Solutions

38 years of industry
experience.

Premium quality products
sourced from reliable brands.

One place for all your sinks,
taps and accessories.

Visit us at
harlynproducts.co.uk



Single Lever
L Spout

Single Lever
L Spout

Lundy-BS	Brushed Steel
RRP	£152.97

Lundy-CH	Chrome
RRP	£139.78

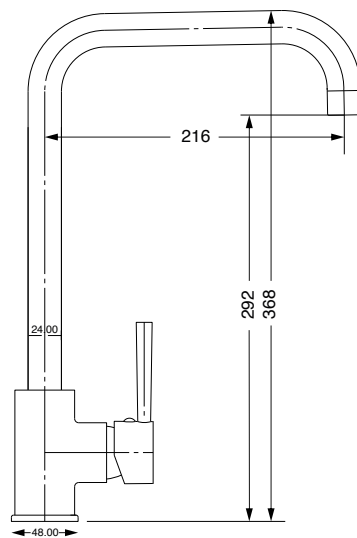



HARLYN

Trelyn

Introducing Trelyn The 4 in 1 Hot Water Tap

Experience the ultimate convenience with Trelyn, Harlyn's innovative 4 in 1 hot water tap collection.

Designed to meet all your hydration needs, Trelyn delivers Hot, Cold, Filtered and 98 degree hot water from a compact 2.5 litre tank that fits seamlessly within your sink unit.

Choose from several exceptional variants, the **Trelyn Flex LED**, our top of the range model featuring electronic controls for precise temperature management; the **Trelyn Flex Twist**, which offers the same outstanding performance with a user friendly lever mechanism and the **Trelyn Modern**, the ideal choice for those seeking a budget friendly yet efficient hot water solution.

Harlyn Trelyn

4 in 1 Hot Water Tap

Four waters, One Source

Each Trelyn Flex tap comes with an interchangeable flexible hose available in a variety of stylish colours, allowing you to customise your look. All Trelyn hot water taps are WRAS approved and come with a 5 year guarantee against manufacturing defects, ensuring you enjoy both quality and peace of mind.



Trelyn Flex LED
Flex 4 In 1 Hot Water Tap

Trelyn Flex LED
Flex 4 In 1 Hot Water Tap

Trelyn-E-CH

Polished Chrome

RRP

£854.37

Trelyn-E-MB

Matt Black

RRP

£880.75

All our Hot Water Taps are supplied as standard with our WRAS approved 2.4 litre hot water tank and cold water filter kit.

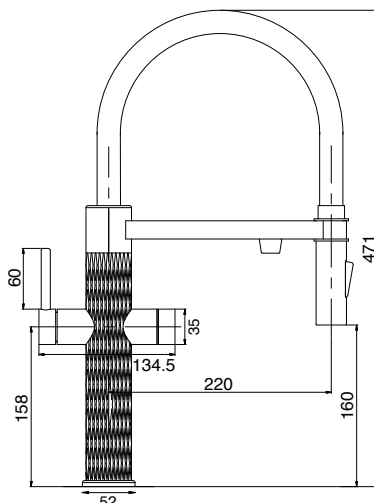



Trelyn Flex Twist offers outstanding performance, with a user friendly lever mechanism.

Harlyn Trelyn Flex Twist

4 in 1 Hot Water Tap



Trelyn Flex Twist
Flex 4 In 1 Hot Water Tap

Trelyn Flex Twist
Flex 4 In 1 Hot Water Tap

Trelyn-T-CH	Polished Chrome
RRP	£828.00

Trelyn-T-MB	Matt Black
RRP	£812.18

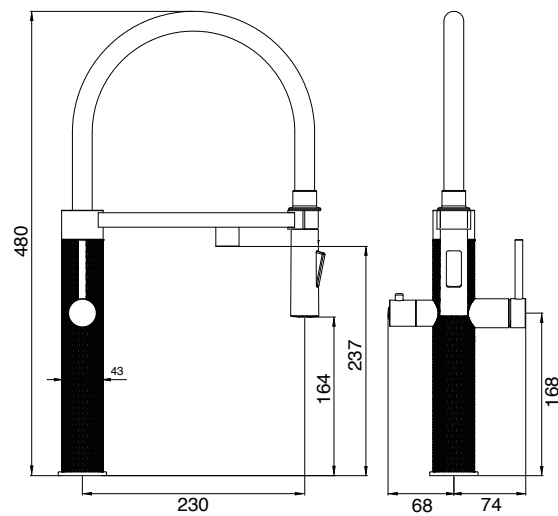



Trelyn Modern, the ideal choice for those seeking a budget friendly yet efficient hot water solution.

Harlyn Trelyn Modern Twist

4 in 1 Hot Tap



Trelyn Modern Twist
4 in 1 Hot Tap Modern

Trelyn Modern Twist
4 in 1 Hot Tap Modern

Trelyn-M-CH
RRP

Polished Chrome
£669.76

Trelyn-M-MB
RRP

Matt Black
£714.59

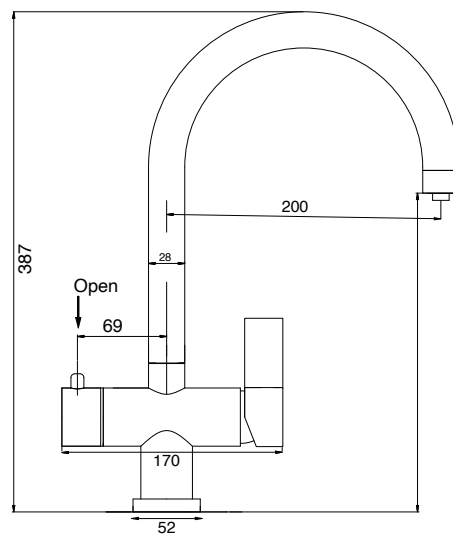

McAlpine Taps

Elegance and sustainability.

Designed to combine style and functionality, these contemporary kitchen taps offer durable finishes and reliable performance. Their water efficient technology and robust construction make them an excellent choice for modern kitchens seeking both elegance and sustainability.





Fast Fit Nut

The easiest taps to install in the market. You will not believe how quickly you can now install basin taps with our patented Fast Fit Nut. Mounting the tap requires no tools.

Simply push the Fast Fit Nut up the thread, then twist it to tighten the last few threads by hand.



Chrome 3+

Introducing our McAlpine tap range made from Chrome 3+ (CR3+).

Most taps are plated in Chrome 6, which is an extremely hazardous substance for both humans and the environment.

Because of our 100+ year history of excellence and quality, we made a decision when we came into this market to plate all our chrome finish taps with Chrome 3+.

- **CR3+ is only 1% of the toxicity of C6.**
- **CR3+ is more energy efficient than C6**

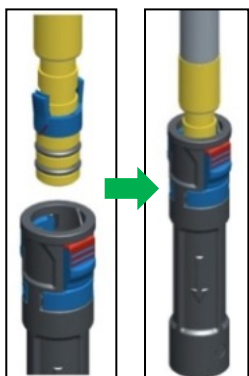

Quick Fit Hose Connector





Kinloch - Rubber Hose/Dual Function

KT-KIN	Chrome
RRP	£306.92

- Easy Installation - Fast Fit Nut Included
- Accredited for WRAS, ACS and DVGW
- Fast Fit Nut for easy installation
- Eco Start Cartridge and energy saving cold start function
- Kitchen Tap with Fast Fit Nut included

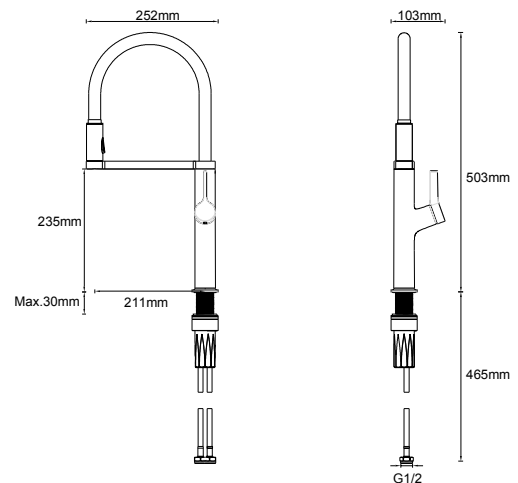



McAlpine Torridon / Teviot

McALPINE



Torridon Single Leaver

Teviot Twin Leaver

KT-TOR	Chrome
KT-TOR-MB	Matt Black
KT-TOR-BB	Brushed Brass
KT-TOR-BN	Brushed Nickel
RRP	£235.38

KT-TEV	Chrome
KT-TEV-MB	Matt Black
KT-TEV-BB	Brushed Brass
KT-TEV-BN	Brushed Nickel
RRP	£235.38

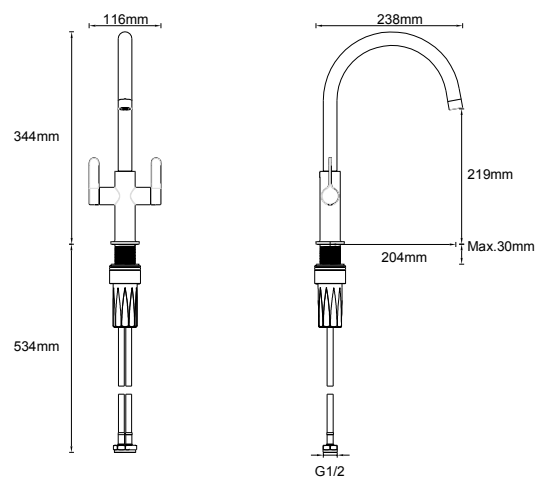
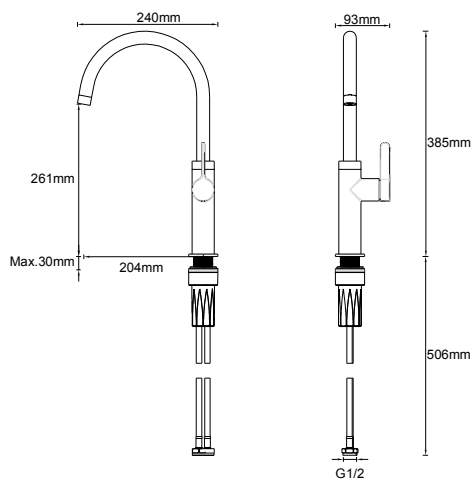





Nethy Top Lever Pull Out

Ness Single Lever Pull Out

KT-NE	Chrome
KT-NE-MB	Matt Black
KT-NE-BB	Brushed Brass
KT-NE-BN	Brushed Nickel
RRP	£235.39

KT-NS	Chrome
KT-NS-MB	Matt Black
KT-NS-BB	Brushed Brass
KT-NS-BN	Brushed Nickel
RRP	£300.00

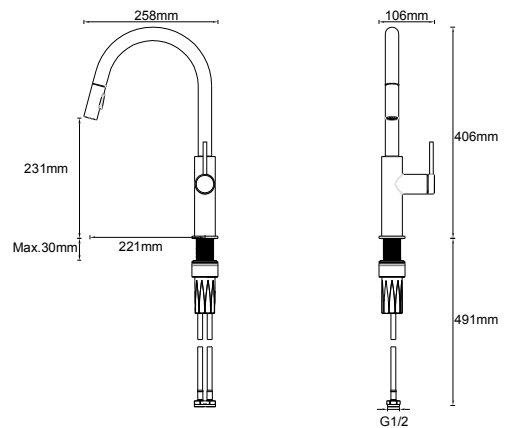
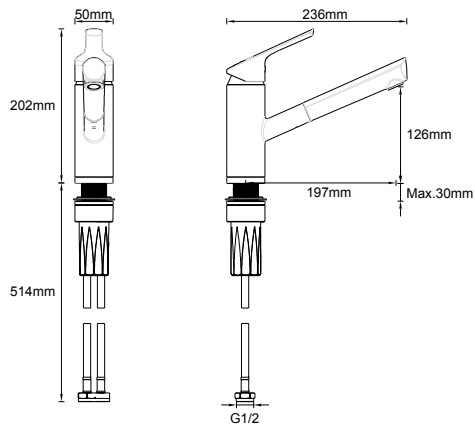

Terms & Conditions

1. GENERAL

- 1.1 In these Conditions the following expressions shall have the following meanings :-
- 1.1.1 "Buyer" means the individual firm company or other party from whom an Order to supply the Goods and/or the Services is received by the Seller
- 1.1.2 "Conditions" means the standard terms and conditions of sale of the Seller as set out herein and includes any additional terms and conditions of sale agreed in writing between the Seller and the Buyer
- 1.1.3 "Contract" means a contract for Supply of Goods and/or Services by the Seller to the Buyer whether made verbally or in Writing
- 1.1.4 "Goods" means the Goods which the Seller is to supply under the Contract
- 1.1.5 "Order" means an order placed by the Buyer for the Supply of the Goods and/or the Services
- 1.1.6 "Recommendations for Use" means the recommendations (if any) relating to the storage, handling, application and/or use of the Goods contained in the published literature of the Seller (or, if relevant, a Supplier) or any recommendations made in writing by an authorised representative of the Seller (or, if relevant, a Supplier)
- 1.1.7 "Seller" means Harlyn Products Limited and any subsidiary or holding company or associate (as such terms are defined in the Companies Act 1985 (as amended)) of the said company and also, where the context so permits, any sub-contractor of the said company or of any subsidiary or holding company or associate (as aforesaid) of the said company
- 1.1.8 "Supplier" means any person, firm or company who or which supplies the Goods and/or the services to the Seller in substantially the form in which they are supplied to the Buyer
- 1.1.9 "Services" means the work or services or any of them to be provided by the Seller under the Contract
- 1.1.10 "Supply" includes, where the context so admits, lease, hire or loan of the Goods
- 1.1.11 "Writing" includes telex, cable, facsimile transmission and comparable means of communication
- 1.2 The Seller reserves the right where there has been no previous course or dealings with the Buyer to insist that the Buyer notifies it in Writing of the full name and address of the Buyer and all its branches and where the Buyer is a limited company the full names and addresses of all its Directors and the names of three persons firms or companies with whom the Buyer has had trade dealings and the name and address of the Buyer's bankers together with authority in Writing for the Seller to contact the same for appropriate references. If the information is not provided within seven days of a request therefore by the Seller or if, following the provision of such information, the Seller is unable to obtain satisfactory trade indemnity or similar cover in respect of its dealings with the Buyer, the Seller may terminate the Contract and the rights and liabilities of the parties shall be the same as if the Contract had been cancelled in accordance with the provisions of Condition 9.2
- 1.3 The Seller reserves the right to assign sub-contract or sub-let the fulfilment of the Contract or any part thereof. The Buyer shall not be entitled to assign the benefit or burden of the Contract without the consent in Writing of the Seller
- 1.4 The Seller shall not be prejudiced by any forbearance or indulgence granted to the Buyer and no waiver of any breach on the part of the Buyer shall operate as a waiver by the Seller of any future breach

2. ORDER, ACKNOWLEDGEMENTS, CONDITIONS AND VARIATIONS

2. Notwithstanding that the Seller may have given a detailed quotation or estimate either verbally or in Writing no Order shall be binding on the Seller unless and until it has been acknowledged in Writing by the Seller or the Goods are delivered or the Services are performed by the Seller to the Buyer pursuant to the Order
- 2.2 These Conditions are incorporated in the Contract and contain the entire obligations between the Seller and the Buyer. In the case of any inconsistency between any letter or quotation incorporating or referring to these Conditions and any Order, letter or form of contract sent by the Buyer to the Seller, whatever may be their respective dates, the provisions of these Conditions shall prevail. In the event of the Seller entering into the Contract without the Seller having submitted a written quotation or other letter or document incorporating or referring to these Conditions but in circumstances where the Buyer has had prior notice of these Conditions then all Goods supplied or Services provided shall be subject to these Conditions.
- 2.3 No variation of a Contract by the Buyer shall be binding upon the Seller unless made in Writing and signed on behalf of the Seller. In the event of such variation the Buyer shall indemnify the Seller in full against all loss, which term shall include (but without prejudice to the generality thereof) loss of profit, costs (including the cost of labour and materials), damages, charges and expenses incurred (directly or indirectly) by the Seller as a result of such variation
- 2.4 Any representations or warranties made by or on behalf of the Seller prior to the Contract (whether verbally or in Writing) are hereby expressly excluded and shall be of no effect

3. DESCRIPTION

- 3.1 Any figures statements descriptions illustrations photographs drawings or any other matters contained in the Seller's catalogues pamphlets price lists or advertising literature are not guaranteed to be accurate and are intended merely to represent a general picture of the Seller's products and services and shall not form part of the Contract
- 3.2 The Buyer recognises that the Seller is a distributor of the Goods. Although the Seller will try to notify the Buyer of any variations in the specification of its products of which it is aware the Buyer accepts that the Seller cannot be accountable for the consequences of any variations in the specification of the Goods

4. QUOTATIONS

- 4.1 The Seller's quotations are provisional in so far as they are subject to alteration by reference to any changes in the price of any item to be acquired by the Seller from a third party rates of wages other costs of production and any other circumstances beyond the Seller's control taking place between the date of the quotation and the Buyer's acceptance thereof

5. PRICE

- 5.1 The price payable for the Goods and/or the Services shall be the list price of the Seller current at the date of delivery of the Goods or provision of the Services less any applicable preferential discounts. Any price set out in any quotation shall be considered to have been given solely for information and shall not constitute an obligation on the part of the Seller that it will deliver the Goods or provide the Services at that price
- 5.2 The price payable for the Goods and/or the Services does not include Value Added Tax, which will be charged at the rate applicable at the date of invoice
- 5.3 Unless otherwise stated, the price set out in the Seller's quotation does not include the cost of packaging. Where packaging is included, unless otherwise agreed, it will be to the Seller's standard specification which should be adequate for the normal incidence of competent handling, covered transport and short term indoor storage in a temperate climate. If additional protection is required, the Buyer must specify this before the Contract is made

- 5.4 Unless otherwise agreed in Writing the price does not include the cost of carriage to the contracted place of delivery nor the cost of off-loading of the Goods which should be arranged by the Buyer at its sole risk and expense nor the cost of installation of the Goods. The seller will endeavour to expedite delivery if requested so to do by the Buyer who must specify in Writing the means of transport to be used but the Buyer shall reimburse the Seller for all additional costs the Seller incurs thereby. The Buyer also agrees to pay for any loss or extra cost incurred by the Seller through the Buyer's faulty instructions, lack of instructions or any failure or delay of the Buyer in taking delivery or through any act or default on the part of the Buyer, its servants, agents or employees
- 5.5 Unless otherwise agreed in Writing Goods to be delivered to a Buyer whose address is outside the United Kingdom will be sold F.A.D.

6. DELIVERY

- 6.1 Delivery of Goods shall be deemed to be effected by the Seller at the following times :-
- 6.1.1 Where Goods are sold F.A.D. delivery shall be complete when they are delivered to the entrance gate of a dock in the United Kingdom nominated in Writing by the Buyer
- 6.1.2 Where Goods are delivered by the Seller when the same arrive prior to unloading at the Buyer's premises or at premises nominated by the Buyer or at the nearest accessible road point to such premises
- 6.1.3 Where Goods are delivered by an independent carrier delivery of the same by the Seller to the Buyer shall be deemed to be effected at the time of loading onto the carrier's vehicle
- 6.1.4 Where Goods are to be delivered by container delivery shall be complete when the same are loaded onto transport for delivery to the container depot or loaded into the container whichever is the earlier
- 6.1.5 In the event of Goods being collected by or on behalf of the Buyer by its servants or agents collection as aforesaid will constitute delivery to the Buyer
- 6.1.6 Where Goods are to be delivered by post when the package or parcel containing the Goods is placed in the custody of the postal authorities
- 6.2 Delivery of Services shall be deemed to be effected by the Seller at the time of provision by the Seller of the Services
- 6.3 Whilst the Seller will make every reasonable effort to complete the Contract by the date or dates therein specified for delivery of Goods or provision of Services such date or dates shall only constitute the time by which the Seller expects to effect such delivery or provision but the time for performance of the Contract by the Seller shall not be of the essence of the Contract, the Seller's failure to so deliver or provide by the due date or dates shall not constitute a breach of Contract and the Seller shall not be responsible for any direct or consequential loss resulting therefrom. The Seller may wholly or partly suspend deliveries of Goods or provision of Services and the Buyer shall accept later delivery of such Goods or late provision of such Services unless the Buyer has cancelled the Contract in accordance with the provisions of Condition 9.3

7. QUANTITIES AND INSTALMENTS

- 7.1 Where Goods or Services are delivered or provided by instalments each instalment shall be deemed to be sold under a separate Contract and the party in default in respect of any instalment shall be liable accordingly, but no default in respect of any one instalment shall affect due performance of the Contract as regards other instalments
- 7.2 The Seller will endeavour to deliver the quantity of Goods ordered and every delivery shall be deemed to comply with the Order if there is a surplus or shortage of Goods not exceeding ten per cent
- 7.3 If Goods or Services are to be delivered or provided by instalments, the Seller shall be entitled to invoice each instalment as and when delivery or provision is made and payment for all delivered or provided instalments shall be due notwithstanding the non-delivery or non-provision of other instalments or other default by the Seller. Failure by the Buyer to make payment by the due date for any one instalment for whatever reason shall entitle the Seller to suspend deliveries of Goods or provision of Services under the Contract but without prejudice to any other right the Seller may have under the provisions of these Conditions

8. TERMS OF PAYMENT

- 8.1.1 Unless otherwise agreed the price shall be due and payable at the Seller's offices in sterling thirty days after the day on which the Goods are delivered or the Services are provided or the Buyer is sent a notification that the Goods are in a deliverable state or that the Seller is ready, willing and able to provide the Services (whichever is the earlier). However, the Seller reserves the right (but without prejudice to its other rights under these Conditions) to require payment immediately on delivery of the Goods or provision of the Services or on sending notification that the Goods are in a deliverable state or that the Seller is ready, willing and able to provide the Services if the Buyer has previously failed to make any payment owing to the Seller on the due date or if the Seller has received unsatisfactory credit rating information relating to the Buyer
- 8.1.2 If the Buyer does not pay the whole or any part of the price on the required day then the Seller shall be entitled (upon giving 24 hours notice in Writing of its intention so to do) to withdraw any preferential discount offered to the Buyer and the Buyer shall be bound to pay to the Seller the amount of the invoiced price before deduction of any such preferential discount and the Buyer shall pay to the Seller in force on the amount then outstanding from the required day until the actual date of payment at the rate of 4 percentage points over the base rate of National Westminster Bank PLC from time to time in interest which shall accrue on a daily basis
- 8.1.3 So long as any payment due from the Buyer to the Seller is outstanding, whether under the same or any other Contract or transaction the Seller shall have a lien on any Goods in its possession and it shall be entitled to retain them and/or suspend work on any Contract
- 8.2 Payment may not be delayed or refused for any alleged defects in the Goods or Services which the Seller undertakes to correct under the terms of its warranty
- 8.3 The Buyer shall not be entitled to withhold payment of any amount due to the Seller by reason of any disputed claim by the Buyer in connection with the Contract nor shall the Buyer be entitled to set off against any amount payable under the Contract to the Seller any amount which is not then due and payable by the Seller or for which the Seller disputes liability

9. SUSPENSION AND CANCELLATION

- 9.1 If the Buyer shall fail to give delivery instructions for or take delivery of the Goods or promptly and diligently carry out any requisite inspection of the Services or make any payment when it becomes due (either under the Contract or under any other Contract between the Seller and the Buyer) or shall commit any other breach of the Contract and fail to remedy the same within seven days of receiving the Seller's request in Writing so to do or makes any voluntary arrangement with the creditors or become subject to an administration order or (being an individual or firm) becomes bankrupt or (being a company) goes into liquidation (otherwise than for the purposes of amalgamation or reconstruction), or an encumbrance takes possession, or a receiver is appointed, of any of the property or assets of the Buyer, or the Buyer ceases, or threatens to cease, to carry on business, or the Seller reasonably apprehends that any of the events mentioned above is about to occur in relation to the Buyer and notifies the Buyer accordingly, the Seller may :-
- 9.1.1 Stop any Goods in transit and suspend further deliveries of Goods or provision of Services and/or
- 9.1.2 Cancel the Contract and if the Goods or Services or any part of them have been delivered or provided but not paid for, the price shall become immediately due and payable notwithstanding any previous agreement or arrangement to the contrary and/or
- 9.1.3 Determine the Contract
- 9.2 But without prejudice to the Seller's right to any unpaid price for Goods delivered or Services provided under the Contract and to damages for loss suffered in consequence of such determination If the Buyer requires cancellation of the Contract this will only be accepted at the sole discretion of the Seller and unless otherwise agreed in Writing only upon condition that any costs charges or expenses (both direct and consequential) incurred by the Seller up to the date of cancellation and the value of all loss or damage (both direct and consequential) incurred by the Seller by reason of such cancellation will be reimbursed by the Buyer to the Seller forthwith. Acceptance by the Seller of any cancellation by the Buyer will only be binding upon the Seller if it is made in Writing
- 9.3 In the event of the Seller other than in any of the circumstances set out in Condition 9.1 being prevented from completing the Contract either wholly or in part in accordance with the terms thereof for any reason whatsoever beyond its reasonable control then further performance of the Contract shall be suspended for the period during which the Seller is so prevented provided that in the event of the Contract being suspended for a continuous period of more than three months then either party may give the other notice in Writing to terminate the Contract forthwith and in such circumstances the Buyer shall pay for all Goods supplied and Services provided to the date of such termination such payment to be made on or before the last day of the month in which termination was effected. The Seller shall be under no liability whatsoever to the Buyer for any direct or consequential loss or damage suffered by the Buyer as a result of the Seller's inability to perform its obligations under the Contract in these circumstances

- 9.4 The Seller shall suspend the performance of the Contract upon receipt of a request in Writing from the Buyer so to do but only for a period not exceeding twenty eight days and the Buyer shall reimburse the Seller for all storage charges and other additional costs the Seller incurs thereby. In the event of the suspension as aforesaid continuing for a period in excess of twenty-eight days then the Seller may terminate the Contract and the rights and liabilities of the parties shall be the same as if the Contract had been cancelled in accordance with the provisions of Condition 9.2

Terms & Conditions

- 9.5 If the Seller shall be prevented from delivering Goods or providing Services in accordance with the Contract as a result of delay or default on the part of the Buyer or any other reason beyond the Seller's reasonable control and the Contract is not cancelled in accordance with the other provisions of this Condition 9 the Seller shall be entitled to reschedule the date or dates for such delivery of Goods or provision of Services to such time or times as it shall reasonably require taking into account its commitments to third parties. The Seller shall also be entitled to be paid storage charges for Goods in the event of such delay or default by the Buyer and notwithstanding Condition 15 such Goods shall be at the sole risk of the Buyer
10. **EXTRA COSTS**
The Buyer will pay to the Seller any extra costs that it incurs as a result of the variation delay or suspension of work arising from any act or omission of the Buyer or any contractor employed by the Buyer or any other circumstances for which the Seller is not responsible
11. **INSTALLATION**
- 11.1. When the Contract provides for the Seller to supervise installation by the Buyer the Seller will supply the necessary competent personnel for supervision purposes only. The Buyer will supply all other necessary skilled and unskilled labour and all equipment and tools for the installation of the Goods
- 11.2. When the Contract provides for actual installation by the Seller, the Seller will supply all necessary personnel and handtools for the installation of the Goods according to the details specified in its quotation
- 11.3. Where installation services are to be provided under Condition 11.1 or 11.2 unless otherwise agreed the Buyer will be responsible for:
- 11.3.1. All necessary preparation of the site including all work to buildings, foundations, supporting structures and fixing points
- 11.3.2. The proper unloading, safe-keeping and insurance of the Goods from the time of delivery
- 11.3.3. The provision of scaffolding, lifting and any other equipment (excluding handtools) and all services required to install or operate the Goods
- 11.3.4. Any work whether preparatory to installation or in the installation itself not specifically included in the Seller's quotation and
- 11.3.5. Giving the Seller access to and possession of the site at such time and in such state as may enable it to complete the installation with any agreed time limit
- 11.4. If the Buyer fails to provide all or any of the items referred to in Condition 11.3 when the Seller reasonably requires them or to its reasonable satisfaction then having given the Buyer an opportunity to remedy its breach of undertaking the Seller may in its discretion and at its sole option arrange for the provision of such item or items as it may require and such expense as may be incurred in providing such item or items shall be payable by the Buyer on demand. A certificate of the Seller's Auditors certifying such amounts shall be conclusive and binding on both parties
12. **CLAIMS FOR DAMAGE IN TRANSIT/SHORTAGES**
- 12.1. Where the Seller is responsible under the Contract for delivery and subject to the provisions of Condition 13.1 the Seller undertakes to make up any shortage or to repair or at its discretion replace free of charge any Goods lost, partially lost or damaged in transit to the contracted place of delivery in which event the time for the delivery of the same shall be extended for such period as the Seller may reasonably require
- 12.2. No claims for non-delivery, partial loss or damage to Goods will be accepted by the Seller unless:
- 12.2.1. Notified in Writing by the Buyer to the Seller (with a copy to the carrier if the Seller's own vehicles were not used) within 7 days after the day of delivery (in the case of partial loss or damage) or 14 days after the date of the invoice (in the case of non-delivery)
- 12.2.2. The Goods in respect of which a claim is made together with the packing are preserved complete and intact as received; for a period of twenty-one days from notification of such claim (or thirty-five days in the case of an export order) and the Buyer permits the Seller or its servants or agents full and free right of access to inspect the Goods and investigate the claim
13. **WARRANTIES AND CLAIMS**
- 13.1. The Goods are not manufactured by the Seller and if they are delivered direct to the Buyer by the Supplier or other third party or collected by or on behalf of the Buyer from the Supplier or other third party the Seller shall not be liable for any loss or damage to such Goods whatsoever or whensoever occurring
- 13.2. The Seller shall use its best endeavours to pass on to the Buyer such benefits relating to warranties in respect of or guarantees of the Goods which the Seller has under contract with the Supplier or other third party, provided the Buyer observes the claims procedure set out in Condition 13.3. Save as aforesaid any warranties conditions or undertakings whether express or implied by statute common law or otherwise howsoever in respect of the Goods are subject to Section 6(1) of the Unfair Contract Terms Act 1977 hereby expressly excluded
- 13.3. Subject always to the provisions of Condition 8, in the event of a claim being made by the Buyer that the Goods or any part thereof are faulty the first recourse is to the manufacturer's warranty and the following procedure shall apply for dealing with such claim:
- 13.3.1. The Seller shall deliver a replacement for the Goods to the Buyer and submit an invoice to the Buyer in respect of such replacement which will be payable in accordance with the provisions of Condition 8
- 13.3.2. The Buyer shall return to the Seller the Goods in respect of which the claim is made complete with all accessories, instruction books, warranty forms as originally delivered to the Buyer
- 13.3.4. If the Seller rejects the claim of the Buyer following inspection it will so advise the Buyer in Writing and the Goods will be held at the Seller's premises for collection by the Buyer for a period of 14 days after the date of the Seller's notice and, if not collected by the Buyer within that time, may be sold by the Seller (without obligation as to price) and the proceeds of sale will be set against the amounts owing to the Seller in respect of the invoice for the replacement Goods and the costs of storage of the Goods in respect of which the claim is made and any other sums due from the Buyer to the Seller on any Contract and any balance remaining will be paid by the Seller to the Buyer
14. **TITLE TO GOODS**
- 14.1. Until payment in full of all monies due and owing by the Buyer to the Seller on any account whatsoever has been received full legal and beneficial ownership of the Goods shall be retained by the Seller notwithstanding that the risk in the same shall pass to the Buyer at the time of delivery
- 14.2. Until payment in full for the Goods has been made the Buyer shall hold the same as fiduciary agent and bailee of the Seller and shall at all times take proper care of the same and/or any products made wholly or partly therefrom and keep them in such manner that they may be clearly identified as belonging to the Seller and the Buyer hereby grants to the Seller the right to enter on the Buyer's premises at any time during the continuation of any Contract to check that the Buyer is complying with the obligation contained in this Condition. The Buyer will return the Goods and/or any products made wholly or partly therefrom to the Seller if it receives a request so to do prior to payment in full having been made
- 14.3. Subject to Conditions 14.4 and 14.5 the Buyer shall be at liberty to sell the Goods and/or any products made wholly or partly therefrom in trust to pay to the Seller such sums to which it is entitled under the provisions of the Contract provided that the sums due to the Seller shall be kept separate from any moneys of the Buyer and/or any third party. Notwithstanding the provisions of this Condition 13 the Buyer may retain from the proceeds of such sale any sum in excess of the sum or sums to which the Seller is entitled under the Contract or any other Contract between the Seller and the Buyer
- 14.4. The Seller may at any time revoke the Buyer's conditional power of sale contained in Condition 14.3 by giving 24 hours prior notice in Writing of such revocation and without notice in the event of the Buyer being in default for longer than fourteen days in the payment of any sum whatsoever due to the Seller from the Buyer (whether in respect of the Goods or under any other Contract between the Seller and the Buyer) or if the Seller has bona fide doubts as to the solvency of the Buyer
- 14.5. The Buyer's conditional power of sale contained in Condition 14.3 shall automatically cease if:
- 14.5.1. A receiver or administrative receiver is appointed over the whole or any part of the assets of the undertaking of the Buyer or a winding up order is made against the Buyer or the Buyer goes into voluntary liquidation (except solely for the purpose of reconstruction or amalgamation) or calls a meeting or makes any arrangement with his or its creditors or becomes subject to an administration order or commits any act of bankruptcy or
- 14.5.2. The Buyer pledges or in any way charges by way of security for indebtedness the whole or any part of the Goods
- And in either event all moneys then due in accordance with Condition 8 shall become payable forthwith notwithstanding the provisions for payment contained in Condition 8 or
- 14.5.3. The Seller has bona fide reason to believe that the Buyer is not complying with the obligations contained in Condition 14.2
- 14.6.1. On determination of the Buyer's conditional power of sale under Conditions 14.4 and/or 14.5 the Buyer shall place the Goods and/or any products made wholly or partly therefrom in the Buyer's possession at the Seller's disposal and the Seller shall be entitled to enter upon the premises of the Buyer for the purposes of removing the same using such force as is reasonably necessary for such purpose
- 14.6.2. If at the time of the determination of the Buyer's power of sale under Conditions 14.4 and/or 14.5 any Goods and/or any products made wholly or partly therefrom are in the custody or control of any individual firm or company other than the Buyer the Buyer shall immediately provide the Seller with an authority in Writing to collect the same and the same shall be at the Seller's disposal
- 14.7. For the purposes of Condition 14.1 the expression "the Buyer" includes any subsidiary or holding company or associate of the Buyer (as such terms are defined in the Companies Act 1985 (as amended))
15. **RISK AND INSURANCE**
- 15.1. The risk in the Goods shall pass to the Buyer at the time of delivery as provided for in Condition 6. The reservation of title contained in Condition 14 shall not affect the Buyer's responsibility to effect such insurance cover which it may consider to be appropriate
16. **ERRORS**
- 16.1. The Seller reserves the right to correct any clerical or typographical errors made by its employees servants or agents at any time
17. **HEALTH AND SAFETY AT WORK ACT 1974**
- 17.1. The attention of the Buyer is drawn to the provisions of Section 6 of the Health and Safety Act 1974. The Seller will make available upon request such information as is in its possession on the design construction and installation of its products to ensure that as far as is reasonably practicable they are safe and without risk to health when properly used. It is the responsibility of the Buyer to take such steps as are necessary to ensure that such information relevant to the Goods which is appropriate is made available to its servants agents or any person to whom the Buyer supplies the Goods and to any other person to whom the Buyer reasonably considers any such information should be given
18. **SAFETY REGULATIONS ON EXPORTED GOODS**
- 18.1. The Goods shall not be used in any country other than that for which the Seller was aware they were originally ordered, without the Seller's consent in Writing
- 18.2. If Goods are to be supplied under the Contract to be used outside the United Kingdom the Buyer shall be deemed to have satisfied itself that such Goods comply with the safety regulations of any country or State in this the Goods are to be so used and the Buyer shall indemnify the Seller in full for any loss or damage whatsoever which the Seller may incur if such Goods do not comply with such Safety regulations
19. **BUYER'S WARRANTIES**
- 19.1. The Buyer warrants to the Seller that:
- 19.1.1. The Buyer will install, operate or otherwise use or store the Goods strictly in accordance with the Recommendations for Use and will all relevant or applicable statutory or other regulations governing the installation, operation, user storage of the Goods
- 19.1.2. Any collection vehicle, container, ship or other means of transport provided by the Buyer or any agent of the Buyer will comply with all relevant legislation and regulations relating to health and safety requirements
- 19.1.3. The storage and transport facilities of the Buyer and all parts thereof and all equipment used in connection therewith is suitable for storage (both short term and long term) and transport of the Goods and complies with any statute, regulation, bye law or other rule having the force of law and relating to the storage of goods of the nature of the Goods
- 19.1.4. Where the Goods are supplied packaged ready for sale the Buyer and its servants, agents and representatives will not tamper with remove or alter the packaging or labels without the prior consent in Writing of the Seller
- 19.1.5. The Buyer will ensure that the Goods are stored at temperatures appropriate to goods of that nature and will comply with any recommendations as to the storage of Goods notified to it by the Seller from time to time
- 19.2. The Buyer shall indemnify the Seller against any claim, loss or damage (including, without limitation, damage to the reputation of the Seller) arising directly or indirectly from any breach of the warranty contained in Condition 19.1
20. **SEVERANCE**
- 20.1. If at any time any one or more of the provisions of these Conditions becomes invalid illegal or unenforceable in any respect under any law or is held by a court to be invalid illegal or unenforceable the validity and enforceability of the remaining provisions hereof shall not in any way be affected or impaired thereby
21. **AUDITOR'S CERTIFICATE**
- 21.1. In the event of a dispute arising between the Seller and the Buyer concerning the sum or sums to which the Seller is entitled in addition to the Contract price as provided for in these Conditions then a certificate from the Seller's auditors certifying such sum or sums shall be conclusive and binding upon the Seller and the Buyer. Any sum certified by such auditors shall be paid by the Buyer on or before thirty days from its receipt of such certificate
22. **JURISDICTION**
- 22.1. These Conditions and each and every Contract made pursuant thereto shall be governed by and construed in all aspects in accordance with the laws of England and the Seller and the Buyer hereby agree to submit to the non-exclusive jurisdiction of the English Courts
23. **GENERAL**
- 23.1. Any notice required or permitted to be given by either party to the other under these Conditions shall be in Writing addressed to that other party at its registered office or principal place of business or such other address as may at the relevant time have been notified pursuant to this provision to the party giving the notice
- 23.2. No waiver by the Seller of any breach of any provision of the Contract by the Buyer shall be considered as a waiver of any subsequent breach of the same or any other provision

Methods of Payment

Methods of Payment

We are able to accept the following methods of payment, subject to conditions.

Bank Transfer

We can accept payment directly into our bank account. All payments must be cleared 24 hours before despatch. Please contact our Credit Control Department for Bank Details.

Delivery

Delivery Charges

Trade Delivery is Free of Charge.

Home delivery will be charged at £30 + VAT Customer's name, address and phone number will need to be provided at the time of placing the order.

Deliveries will only be made to a ground floor entrance by a single driver. Assistance may be required with larger / heavier items. Delivery via carrier may be requested and will be chargeable at the appropriate rate.

Returns

Any goods damaged in transit must be reported to us within 48 hours. Faulty goods will only be collected on proof of a valid manufacturer uplift number.

Any goods which are surplus to requirements must be reported within 7 days of the original delivery date and must be packaged as new. We will charge a 'restocking charge' of 20% on unwanted goods but are unable to collect goods which have been discontinued or ordered specially. All requests for collection must be submitted on Harlyn Products Collection Request forms', which are available from our Sales Desk.

Communication Preferences

You receive this publication as a customer of Harlyn Products Limited

If you no longer wish to receive this publication please email: info@harlynproducts.co.uk

Contact Us

Sales Enquiries:

01452 222468

Email:

info@harlynproducts.co.uk

sales@harlynproducts.co.uk

Website:

harlynproducts.co.uk



HARLYN

Products

premium product solutions

info@harlynproducts.co.uk | harlynproducts.co.uk